

TX™ SERIES

Model TX-LC2

Active Audio Combiner/ Balanced Line Converter

ANYWHERE YOU NEED...

- To Mix Two Unbalanced Audio Signals to Mono Balanced
- To Combine Stereo Into Mono with Balanced Output
- A Gain-Trim For an Output
- Isolation Between Inputs
- Unbalanced to Balanced Conversion
- High Quality Audio

You Need The TX-LC2!



The TX-LC2 is part of the group of versatile TX series products from Radio Design Labs. The TX series feature the advanced circuitry for which RDL products are known, combined with durable, quality connectors. The ultra-compact TX series can be mounted in limited space using the adhesive methods popularized by RDL's STICK-ON® Series. The TX-LC2 may be mounted directly to a backboard or chassis using a variety of mounting options available from RDL.

APPLICATION: The TX-LC2 is the ideal choice in installations requiring the active, isolated mixing of two unbalanced line-level audio sources to feed a balanced (or unbalanced) audio output.

The input circuits are high-impedance, line-level (-10 dBV) and are isolated from each other. Therefore the modules may be used to bridge an unbalanced stereo source without affecting the stereo separation. The output from the TX-LC2 is a mono mix of the stereo signal. Gain of the combined signals is adjustable from Unity to 14 dB.

The TX-LC2 may also be used to mix two separate sources into a single output. The mixing circuit in the module is an active summing amplifier.

The output driver provides a 150 Ω balanced source to drive high or low impedance, balanced or unbalanced lines. The TX-LC2 may be operated from any power supply voltage between 24 and 33 Vdc, and as low as 12 Vdc with reduced headroom. The module's normal operating voltage is 24 Vdc.

The input connectors make connection of the TX-LC2 easy. The broad gain range makes the TX-LC2 ideally suited to any installation where a balanced mono signal is needed from a stereo unbalanced source, particularly low-output consumer products such as certain televisions. Use the TX-LC2 individually, or combine it with other RDL RACK-UP®, STICK-ON, TX or FLAT-PAK™ series audio or video modules as part of a complete audio/video system.

TX™ SERIES

Model TX-LC2

Active Audio Combiner/ Balanced Line Converter

Installation/Operation



EN55103-1 E1-E5; EN55103-2 E1-E4
Typical Performance reflects product at publication time
exclusive of EMC data, if any, supplied with product.
Specifications are subject to change without notice.

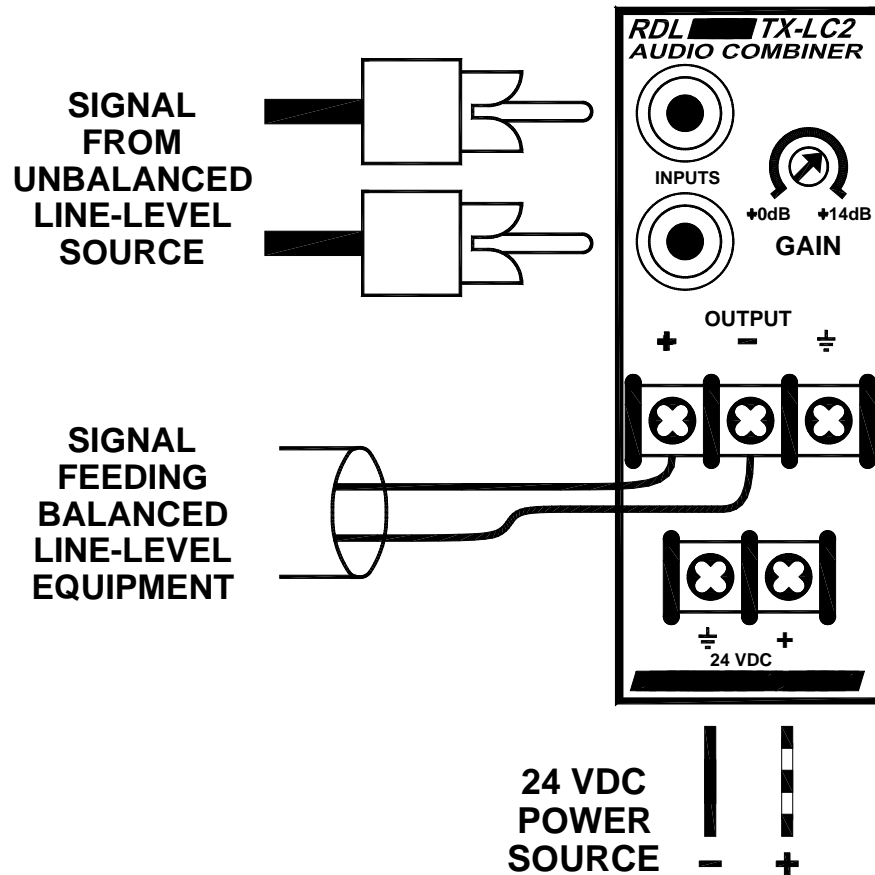

TYPICAL PERFORMANCE

Inputs (2):	-10 dBV nominal, -22 dBV minimum
Input Impedance:	10 k Ω bridging
Noise:	< -85 dB below +4 dBu (-10 dBV input @ 12 dB gain)
THD+N:	< 0.005%
Frequency Response:	10 Hz to 20 kHz (into bridging input) 25 Hz to 20 kHz (into 600 Ω)
Gain:	Unity to +14 dB nominal (adjustable)
Intermodulation Distortion:	0.010% typical
Output:	150 Ω Balanced, +4 dBu to drive low or high impedance balanced or unbalanced lines
Headroom:	> 18 dB
Power:	24 to 33 Vdc @ 30 mA, Ground-referenced
Dimensions:	Height: 1.4 in. 3.6 cm Length: 3.0 in. 7.6 cm Width: 1.2 in. 3.0 cm

Radio Design Labs Technical Support Centers

U.S.A. (800) 933-1780, (928) 778-3554; Fax: (928) 778-3506

Europe [NH Amsterdam] (+31) 20-6238 983; Fax: (+31) 20-6225-287