



RDL[®]
Radio Design Labs

SPECIALISTS IN PRACTICAL PRECISION ENGINEERING™

RM-MP12A

Rack Mount 12-Channel Audio Monitor Panel

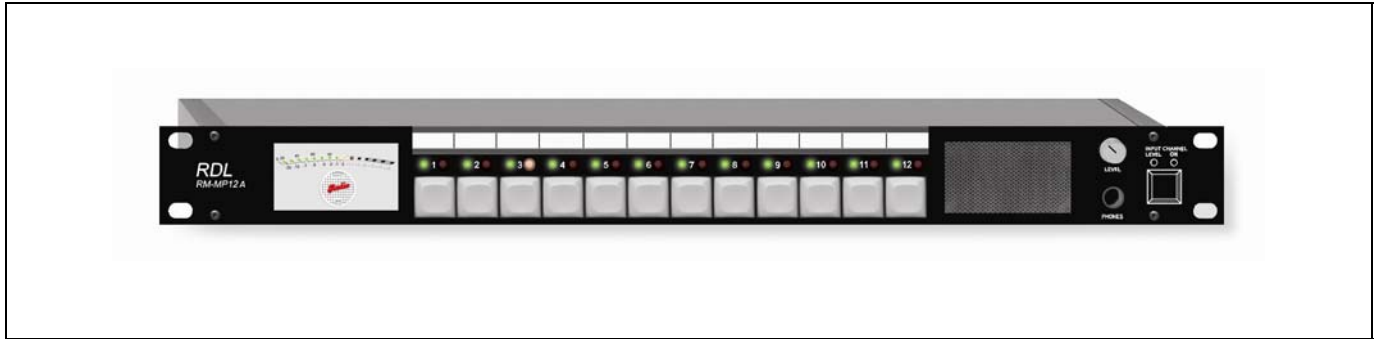

- Twelve Individually Selectable Audio Inputs Using High Quality Keyboard-Style Pushbuttons
- Selectable Operating MODE Provides Interlocking Source Selection or Mixing Multiple Sources
- LED Above Each Button to Show Selected Source
- Variable Intensity *VU Ballistic* LED Provided Above the Button for Each Audio Input
- Rear-Panel Switches Set Each Input Level Range for +4 dBu, 25 V, 70.7 V or 100 V
- Input Signals May Be: Balanced, Unbalanced, Constant Voltage Speaker Line or 8 Ω
- Installer Adjustable Trimmers Permit Calibrating Each Input for Normal Operating Levels In the Selected Range
- Calibrated Front-Panel Meter Displays Selected Audio Source
- Meter Calibrated to 0 dB Scale, with Full Metering Above and Below 0 dB
- Meter Scale: -18, -10, -8, -6, -4.5, -3, -2, -1, 0, +1.5, +3, +6, +10, +14, +18
- Front-Panel Speaker and Headphone Jack
- Level Control for Speaker and Headphone Uses VCA for Long, Noise-Free Life
- Internal 4.5 W RMS Power Amplifier Feeds Either Internal Speaker or External Speaker
- Fixed Line-Level +4 dBu Output
- Variable Line-Level +4 dBu Output (Controlled by Front-Panel Knob)
- Audio Inputs and Outputs on Plug-In Terminal Blocks
- Differential Inputs Feature Very High Common Mode Rejection for Minimum Hum

Wherever monaural line level or speaker level audio needs to be selected and/or monitored economically with professional quality, reliability, and in a single rack unit, the RM-MP12A is the ideal choice. Use the RM-MP12A individually, or combine it with other RDL products as part of a complete audio/video system.

APPLICATION: The RM-MP12A is the ideal choice in rack mount audio monitoring or source selection applications where various audio levels need to be selected and/or monitored. Each input may be individually calibrated for unbalanced consumer, balanced professional, 8 Ω speaker line or constant voltage speaker lines. There is a variable intensity LED on the front panel for each input (full intensity at 0 dB to minimal intensity at -15 dB). These simple meters remain active at all times providing an immediate visual indication of correct operating levels for all inputs simultaneously. Front-panel pushbuttons select one of the twelve inputs to feed the calibrated meter, front-panel speaker (or external speaker if connected) and headphone jack. The 0 dB LED on the calibrated meter indicates a +4 dBu output at the fixed level output. Normal operating levels in distributed speaker systems are typically less than full power (for example, normal operating level may be several dB less than 70.7 V or 100 V). A rear-panel calibration control is provided for each of the twelve inputs permitting each individual level to be calibrated to 0 dB on the meters. With the input level set, the variable intensity LED for a given input will indicate the same level as the expanded scale meter indicates when that source is selected.

The front panel features 12 high-reliability, keyboard-style pushbuttons with corresponding LED indicators to show which audio source is selected. In the MIXING mode, each button alternately selects and deselects an audio source. Multiple sources may be selected at the same time. In the INTLK (interlocking) mode, pressing a button selects the corresponding source and deselects all other sources. If the button for an active source is pushed, all audio sources are turned off until the next source selection is made. The front-panel volume knob controls the audio level of the front-panel headphone jack, front-panel speaker, external speaker output and variable line level (+4 dBu) rear-panel output. A separate fixed +4 dBu line-level output on the rear panel is always active and unaffected by the front-panel control. The front-panel control uses a VCA for long-life, noise-free performance. During installation of the RM-MP12A, either the front-panel speaker or external speaker is selected. Inserting headphones into the front-panel jack will optionally (based on rear-panel switch setting) mute the speaker.

RM-MP12A

Rack Mount 12-Channel Monitor Panel

Installation/Operation



EN55103-1 E1-E5; EN55103-2 E1-E4
Typical Performance reflects product at publication time exclusive of EMC data, if any, supplied with product. Specifications are subject to change without notice.

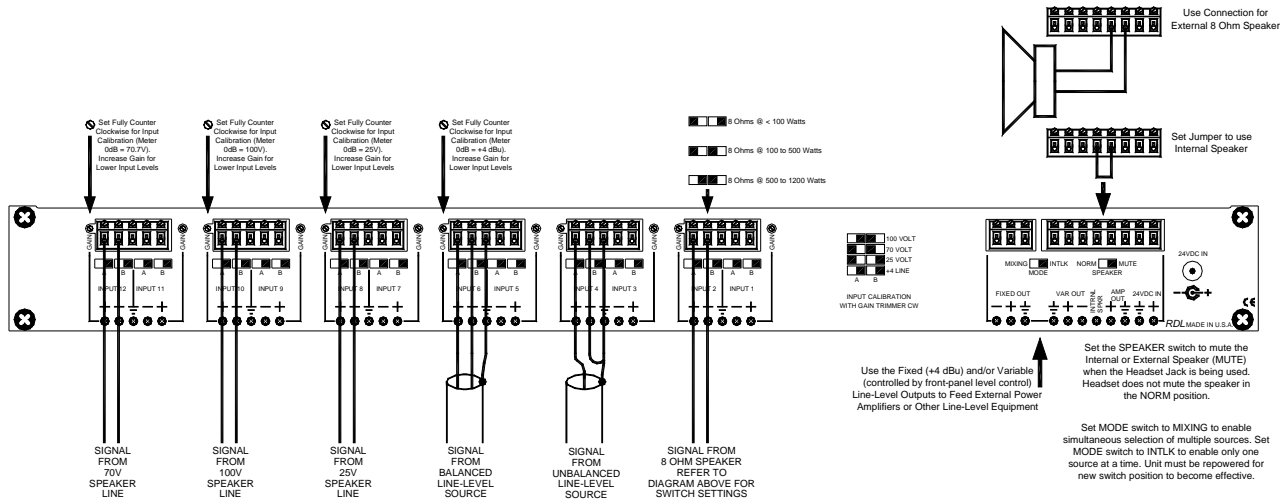

TYPICAL PERFORMANCE

Inputs (12):	+4 dBu, 25 V, 70.7 V, 100 V, 8 Ω (set by rear-panel switches)
Input Level:	-11 dBu to +9 dBu (+4 dBu input) 25 V, 70.7 V, 100 V (calibrated with gain trim set fully counter-clockwise) > 18 dB (above calibrated input level)
Headroom:	> 18 dB (above calibrated input level)
Gain:	0 dB to 20 dB (Adjustable for speaker-level input, 25-turn trim potentiometer) -5 dB to 15 dB (+4 dBu input)
Frequency Response:	10 Hz to 20 kHz (+/-0.25 dB)
THD+N:	< 0.010% (20 Hz to 20 kHz)
Intermodulation Distortion:	< 0.025% (20 Hz to 20 kHz)
Channel to Channel Crosstalk:	< -80 dB (10 Hz to 20 kHz)
Residual Noise:	< -80 dB (Channel ON; referred to +4 dBu)
OFF Attenuation:	> 80 dB (10 Hz to 20 kHz)
Indicators per Channel (2):	Red LED above selection button indicating active channel; Variable intensity LED above the button for each audio input indicates audio level (minimum intensity at -15 dB, maximum intensity at 0 dB)
CMRR:	> 75 dB (50 Hz to 120 Hz)
Outputs (4):	150 Ω , +4 dBu fixed level (balanced or unbalanced via plug-in terminal block) 150 Ω , +4 dBu variable level (balanced, controlled by front-panel volume control) 4.5 W RMS external speaker connection (use of external speaker disconnects internal speaker) 100 mW ¼-inch stereo headphone jack
Power Requirement:	24 to 33 Vdc @ 700 mA, Ground-referenced
Mounting:	Standard 19" Rack-mount; 1 Rack Unit (RU)
Dimensions:	Height: 1.75 in. 4.4 cm Length: 19.0 in. 48.3 cm Depth: 5.35 in. 13.6 cm

NOTE: This equipment has been tested and found to comply with the limits for a Class B digital device, pursuant to part 15 of the FCC Rule. These limits are designed to provide reasonable protection against harmful interference in a residential installation. The equipment generates, uses and can radiate radio frequency energy and, if not installed and used in accordance with the instructions, may cause harmful interference to radio communications. However, there is no guarantee that interference will not occur in a particular installation. If this equipment does cause harmful interference to radio or television reception, which can be determined by turning the equipment off on, the user is encouraged to try to correct the interference by one or more of the following measures:

- Reorient or relocate the receiving antenna
- Increase the separation between the equipment and receiver
- Connect the equipment into an outlet on a circuit different from that which the receiver is connected.
- Consult the dealer or an experienced radio/TV technician for help.